



60 minutes



CAIS

CONNECT 60 ASSEMBLY MANUAL



VIDEO
MANUAL

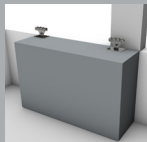
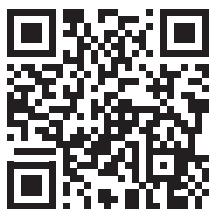

CONSTRUCTION
SITE PREPARATION

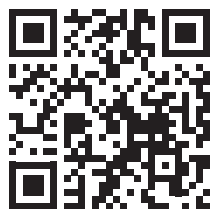

DIAGON 60
SETTING

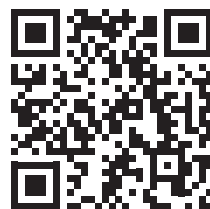

CAIS
CATALOG

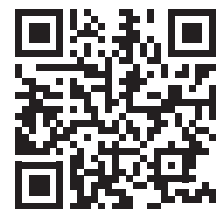

CONNECT 60 - 4.0/1.5

CODE	ART.	PCS
	FRAME 1.5	1 pc
	KIT - BOLTS, NUTS	1 pc
1700004	RUN S	1 pc
1700005	LAST S	1 pc
1700007	PILOT SN	2 pcs
1700174	SPEED SE	2 pcs
1700237	DIAGON 60	1 pc
1700339	JRS 30	1 pc
1700359	PARK CSM	1 pc
1700367	DOCKER O	1 pc
1720016	STAGE SZ 2,8	2 pcs

Total weight = 142 kg

CODE: 1710802

CONNECT 60 - 4.0/1.3

CODE	ART.	PCS
	FRAME 1.3	1 pc
	KIT - BOLTS, NUTS	1 pc
1700004	RUN S	1 pc
1700005	LAST S	1 pc
1700007	PILOT SN	2 pcs
1700174	SPEED SE	2 pcs
1700237	DIAGON 60	1 pc
1700339	JRS 30	1 pc
1700359	PARK CSM	1 pc
1700367	DOCKER O	1 pc
1720016	STAGE SZ 2,8	2 pcs

Total weight = 139 kg

CODE: 1710801

CONNECT 60 - 4.0/1.1

CODE	ART.	PCS
	FRAME 1.1	1 pc
	KIT - BOLTS, NUTS	1 pc
1700004	RUN S	1 pc
1700005	LAST S	1 pc
1700007	PILOT SN	2 pcs
1700174	SPEED SE	2 pcs
1700237	DIAGON 60	1 pc
1700339	JRS 30	1 pc
1700359	PARK CSM	1 pc
1700367	DOCKER O	1 pc
1720016	STAGE SZ 2,8	2 pcs

Total weight = 135 kg

CODE: 1710800

RUN S



1700004

LAST S



1700005

PILOT SN



1700007

SPEED SE



1700174

DIAGON 60



1700237

JRS 30



1700339

PARK CSM



1700359

DOCKER O



1700367

STAGE SZ 2,8



1720016

SECTION 1

HEIGHT	WEIGHT
mm	kg
1500	21
1300	20
1100	19

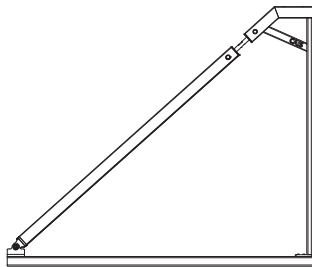
**SECTION 2**

HEIGHT	WEIGHT
mm	kg
1500	28,5
1300	27
1100	25,5

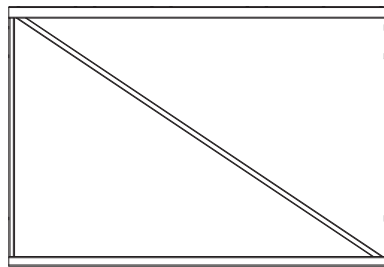
**SECTION 3**

HEIGHT	WEIGHT
mm	kg
1500	28,5
1300	27
1100	25,5

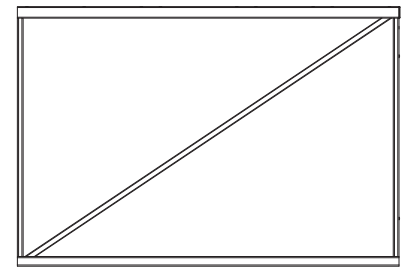
**MAXIMUM LOAD ON THE GATE FRAME 125 kg**

TOWER 1.5

Total weight = 15 kg

CODE: 1710805

**TOWER 1.3**

Total weight = 13,5 kg

CODE: 1710804

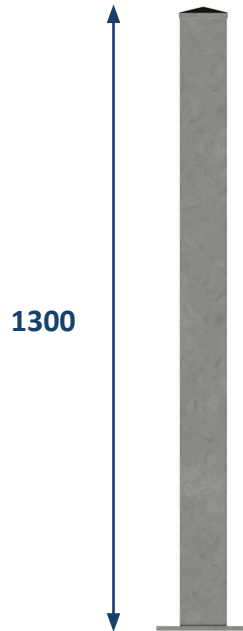
**TOWER 1.1**

Total weight = 12 kg

CODE: 1710803

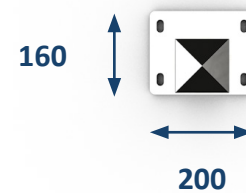
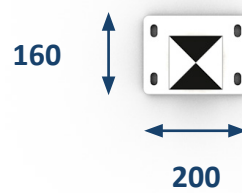
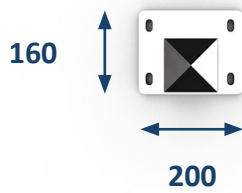
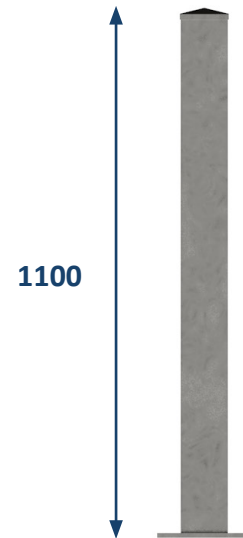
***NOT INCLUDED IN SET CONNECT 60**

DRIVEWAY 4000 mm

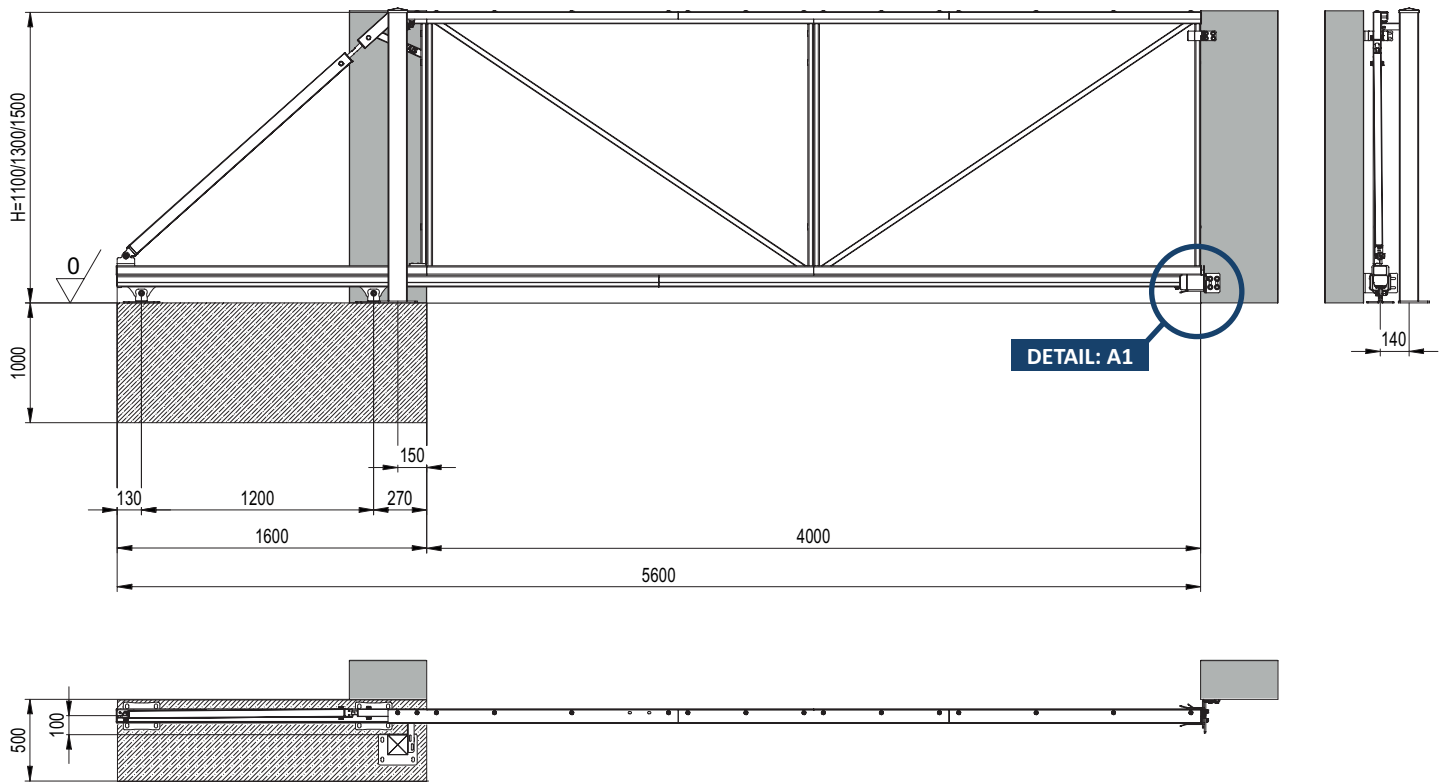

A1 (1:20)

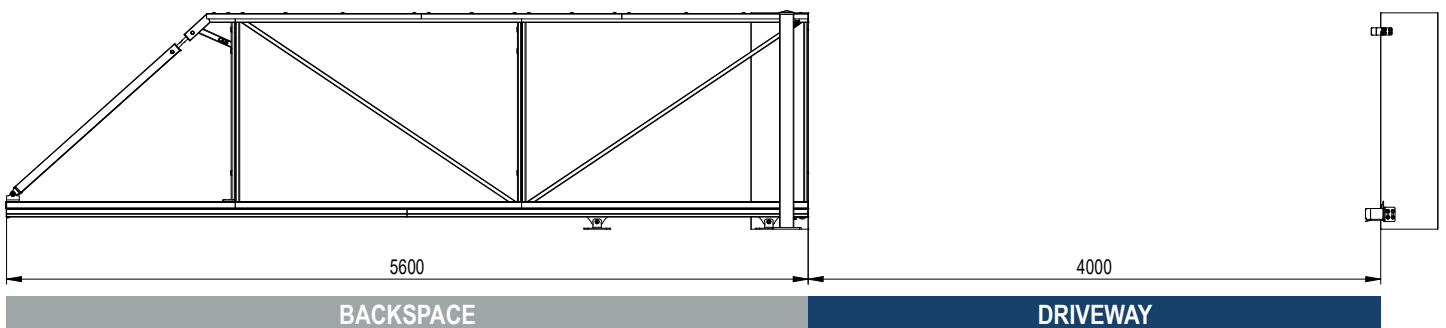
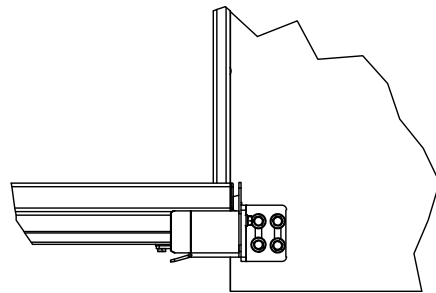

DRIVEWAY 3900 mm

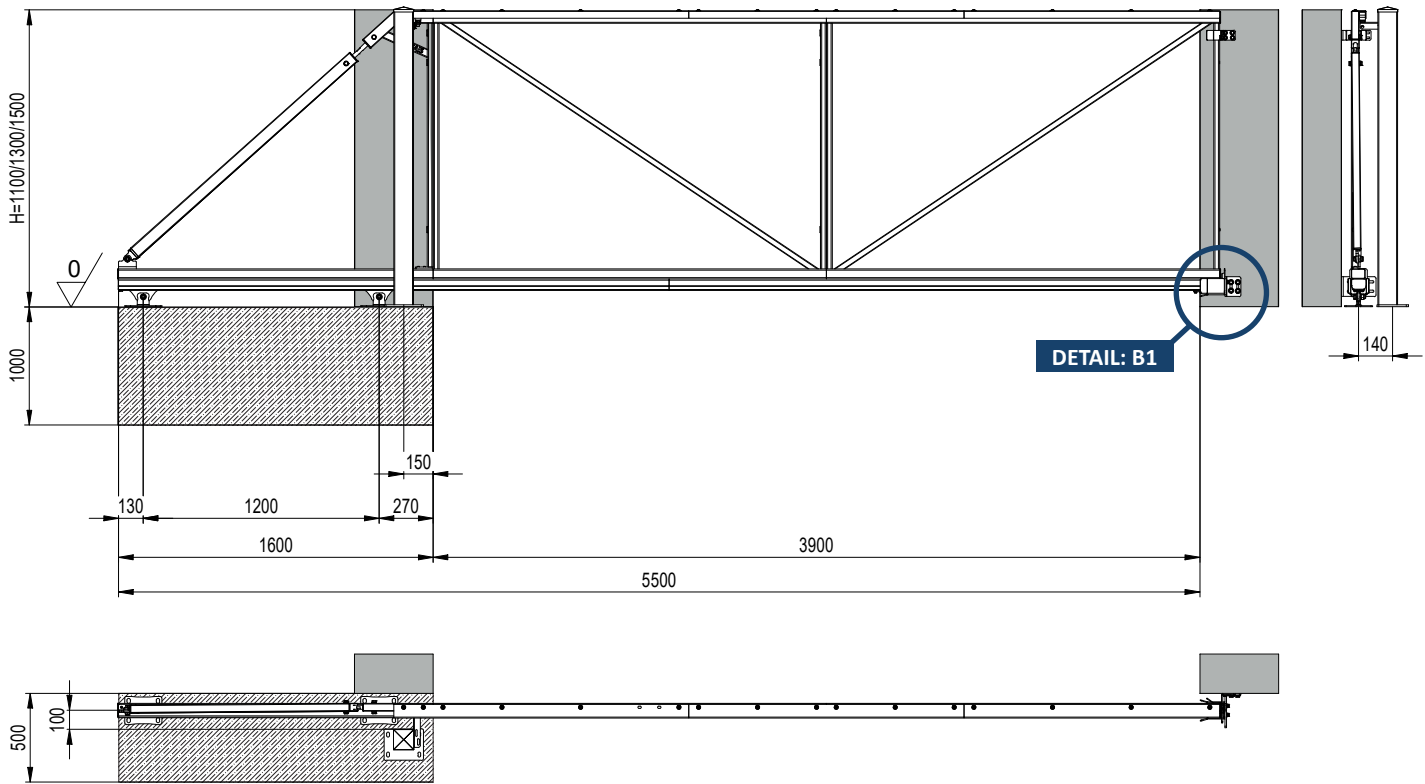

B1 (1:20)

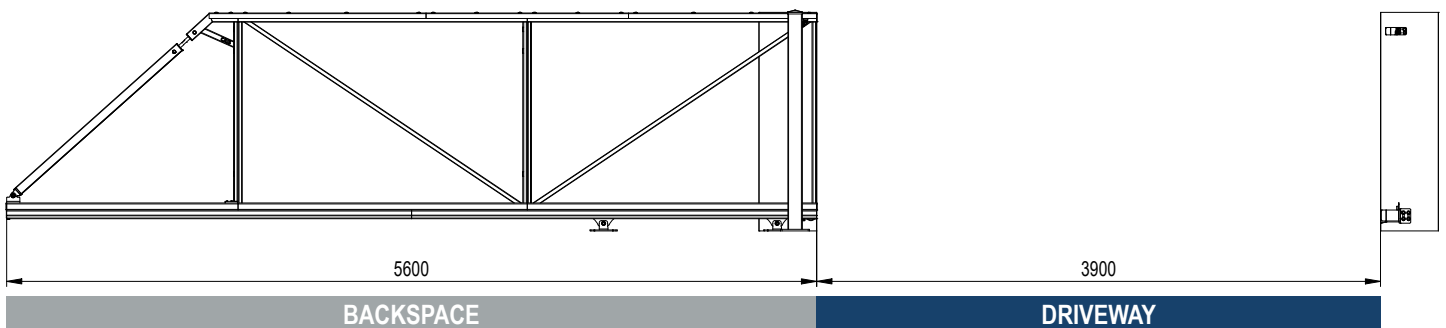
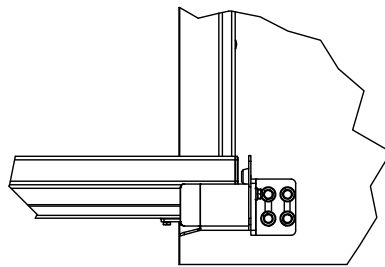

CONNECT 60

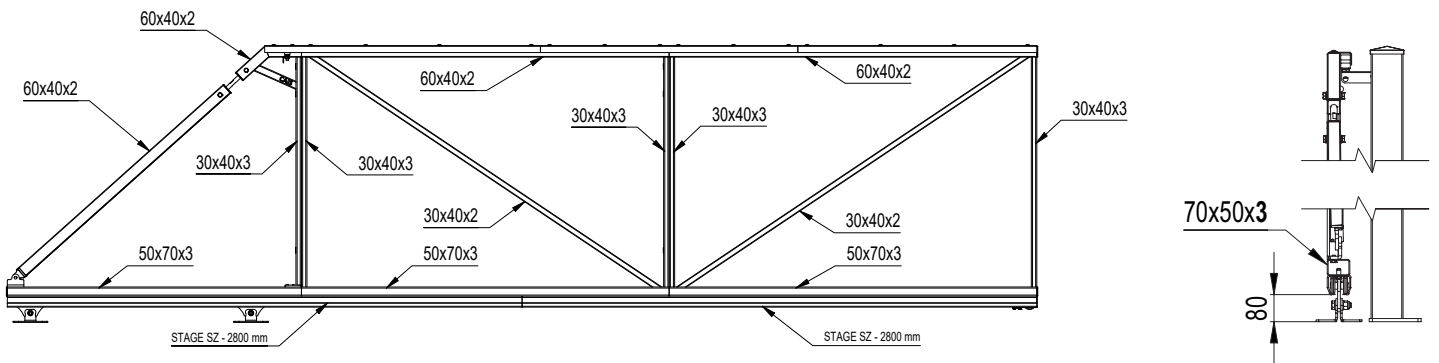

MAXIMUM LOAD ON THE GATE LEAF 125 kg

CERTIFICATION



CONNECT 60

REPORT OF ASSESSMENT OF PERFORMANCE
NO.755200134 / 2022

Notified Body No. 1023

**INSTITUTE FOR TESTING
AND
CERTIFICATION**

Třída Tomáše Bati 299
763 02 Zlín, Czech Republic
Division CSI - Centre of Civil Engineering



Assessed by
Ing. Vratislav Glos

26.05.2022

MANAGING DIRECTOR
Mr. Miroslav Cais



CAIS s. r. o.
Přehradní 199
763 16 Fryšták
Czech Republic



CONNECT 60

CANTILEVER GATE

22

EN 13241:2003+A2:2016

Serial number: 600000

Date:

Resistance

to wind load: Class

2006/42/ES

PATENT

OFFICE PŘÍKRYL

has registered at industrial
property office for **GERMANY**
the utility model number
20 2015 103 846
for **E-BOX** cantilever gate,
produced by **CAIS s.r.o.**

ASSEMBLY MANUAL

TOOLS

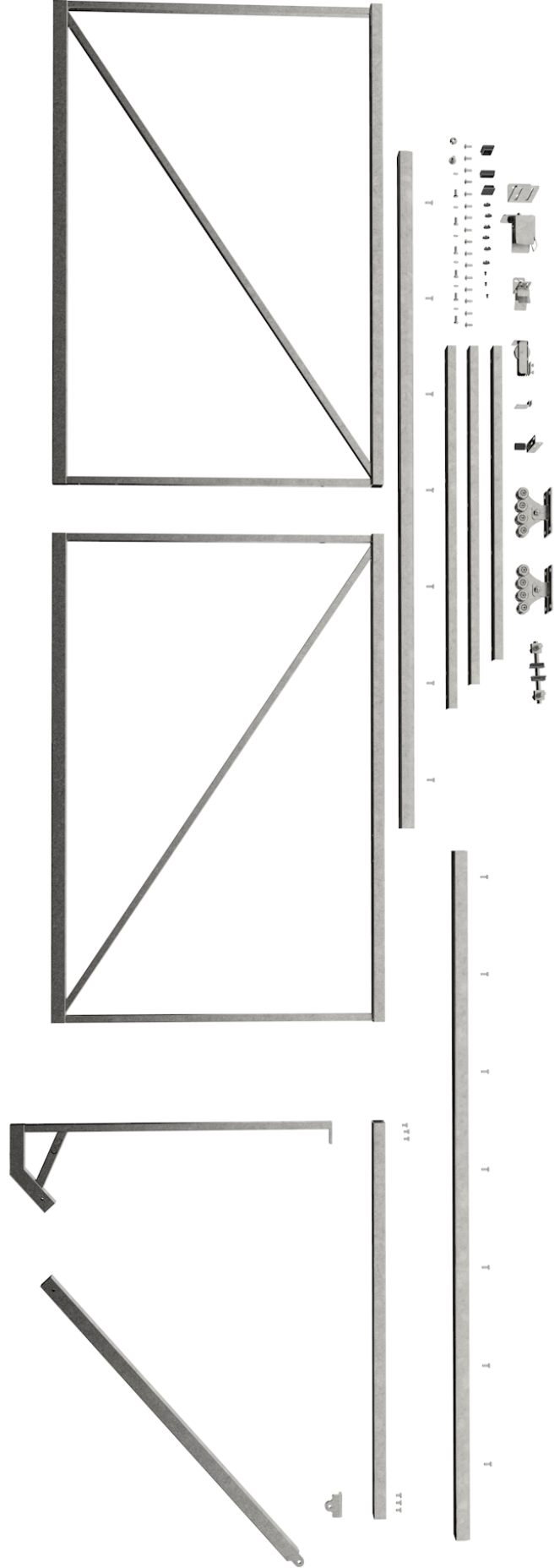
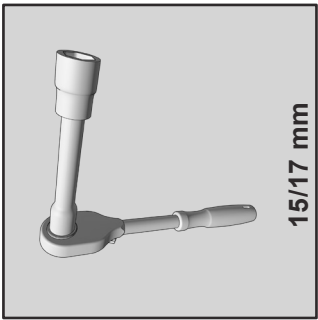
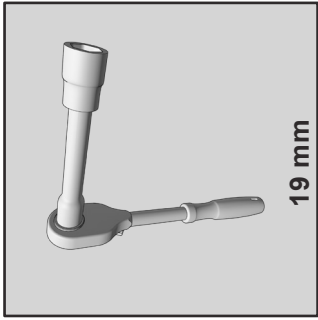
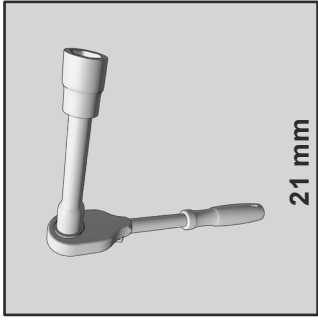
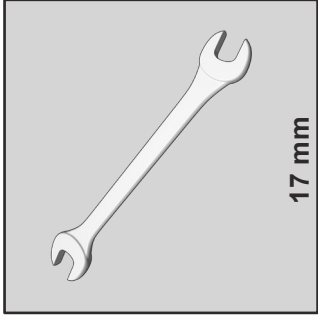
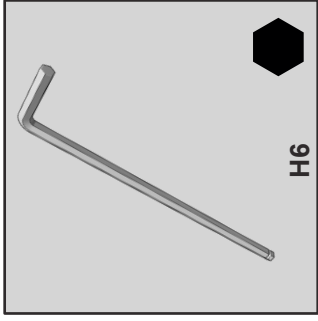

ASSEMBLY MANUAL

1

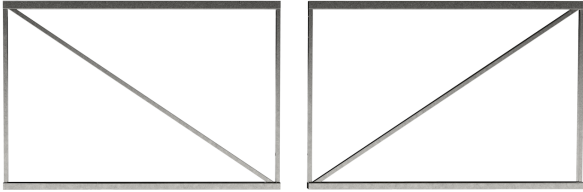

2



3

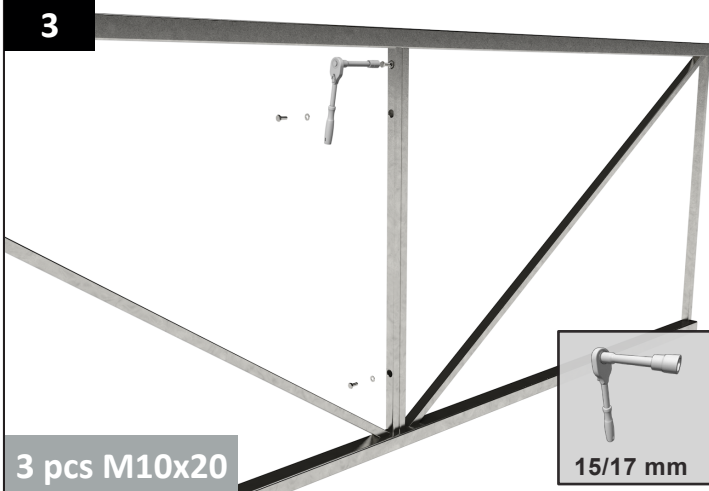

4



5

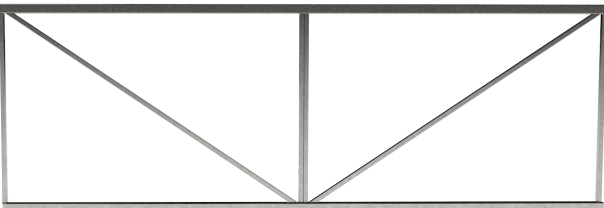



A - LEFT OPENING



6 A

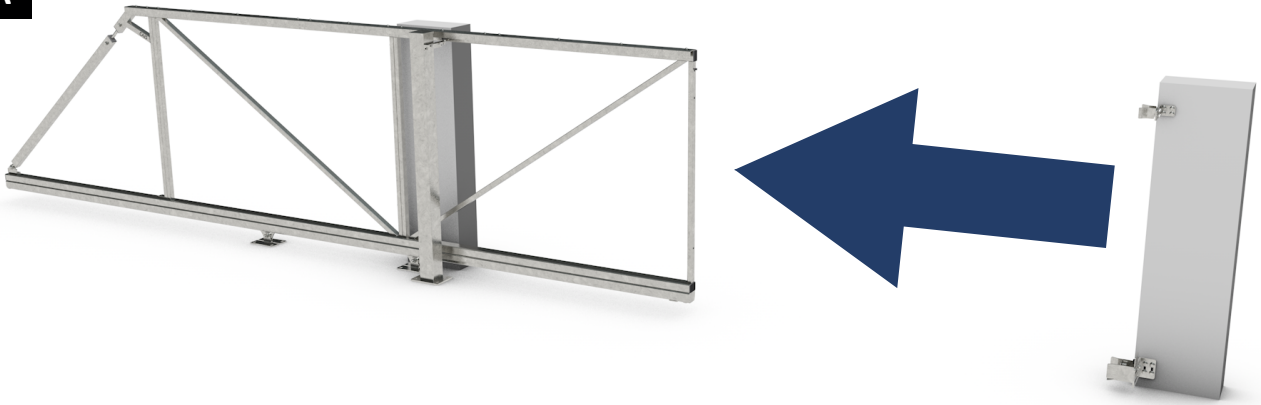

7 A

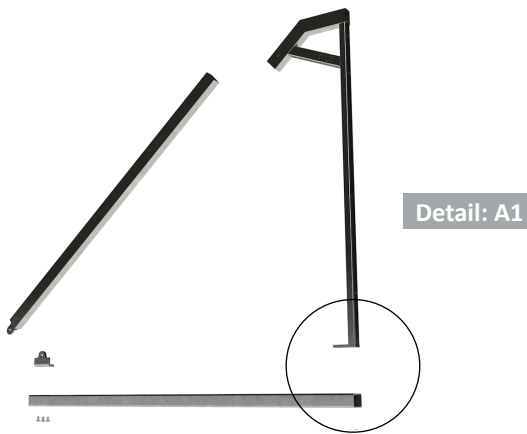

8 A

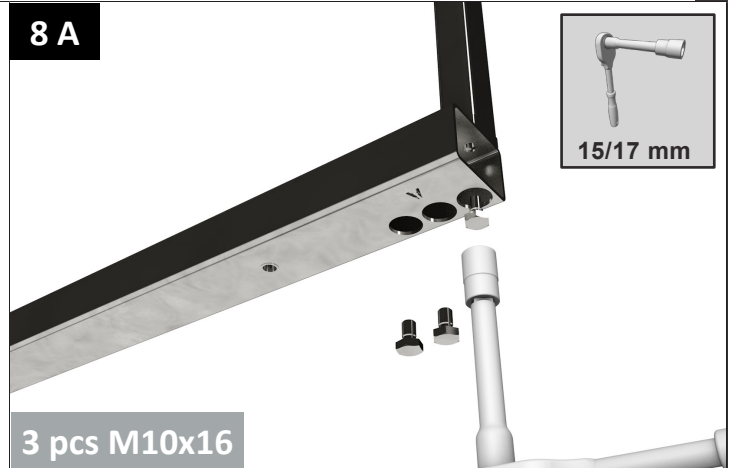

9 A

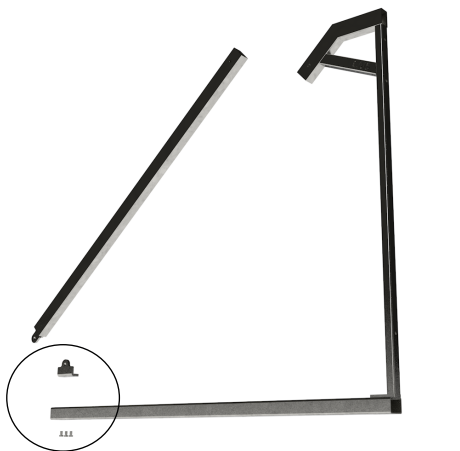

10 A

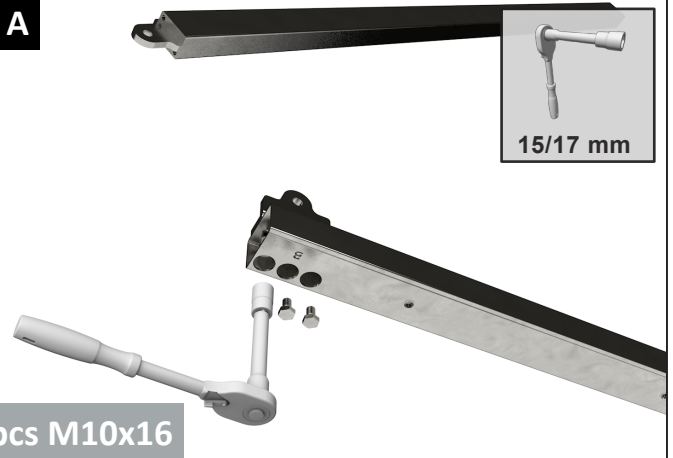

11 A

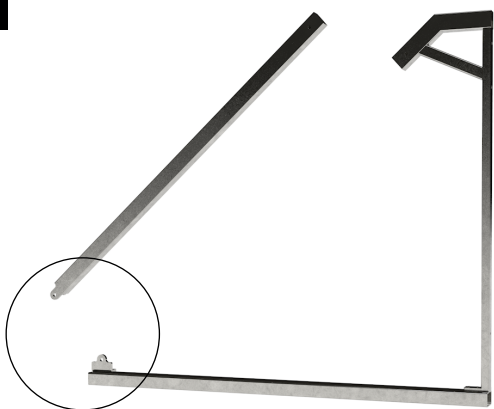

12 A

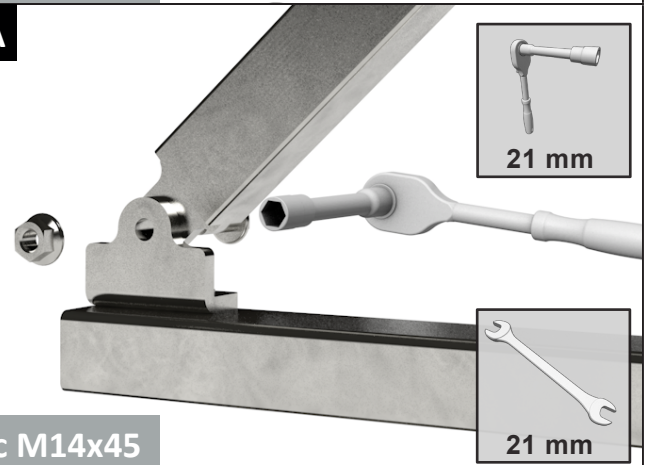



B - RIGHT OPENING



6 B

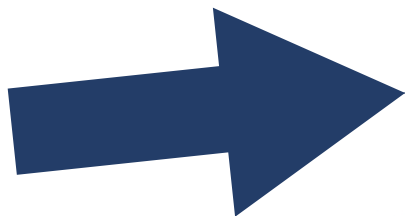

7 B



8 B



9 B



10 B

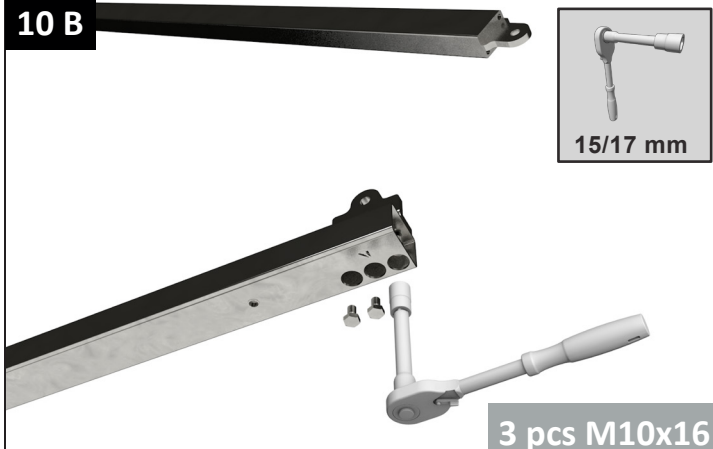

11 B

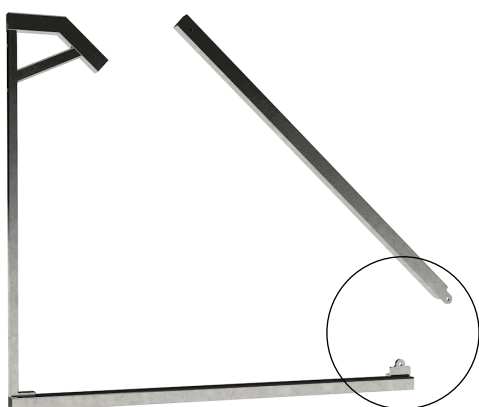

12 B

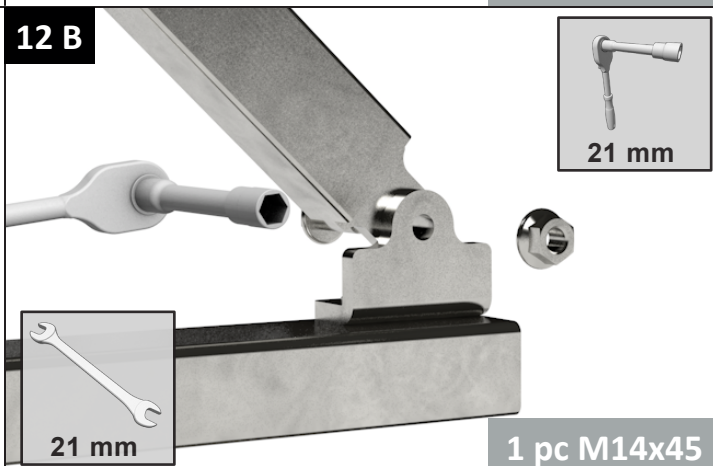

12

13

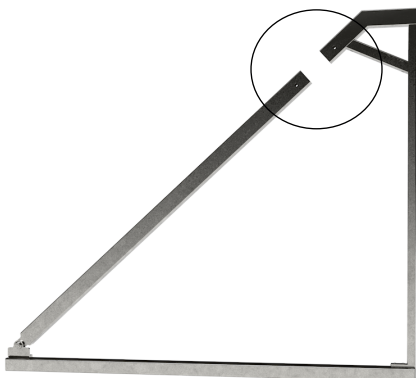

14



19 mm

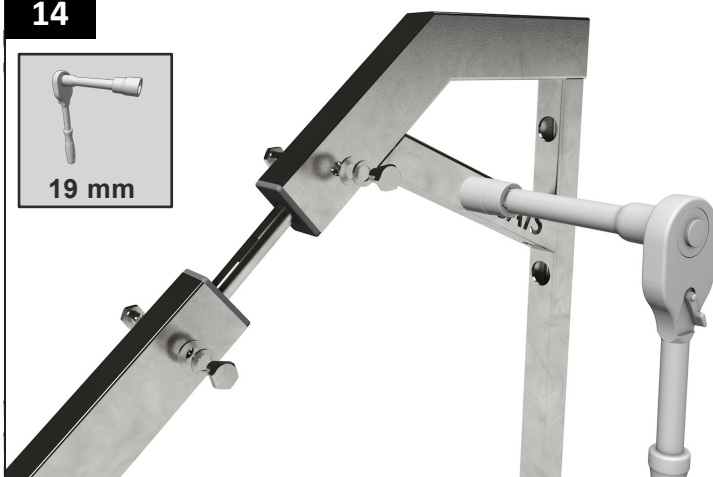

15

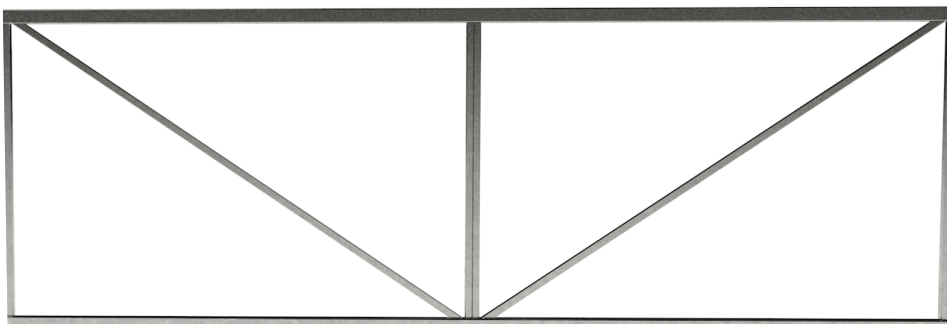

16

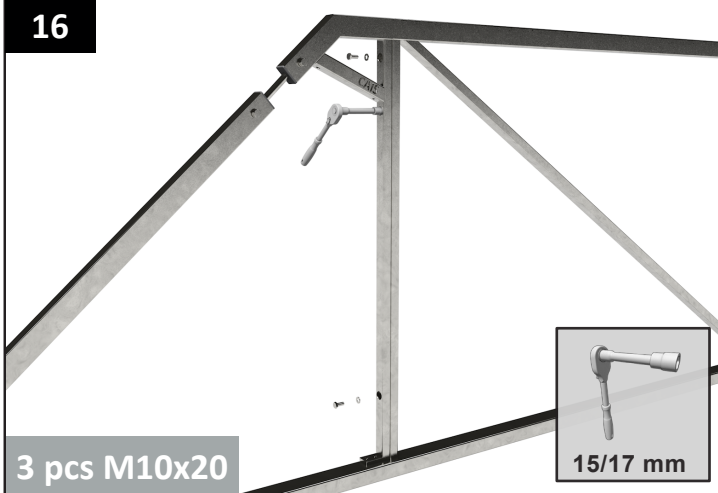

3 pcs M10x20



15/17 mm

17



18

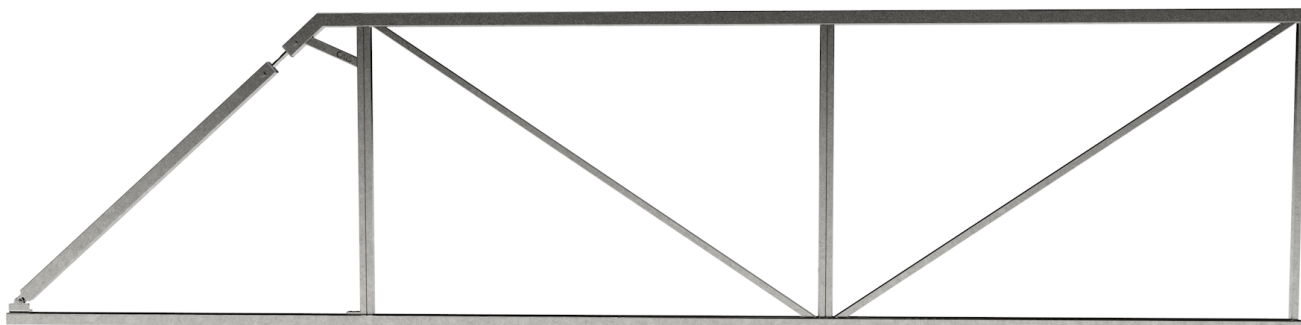

A - LEFT OPENING

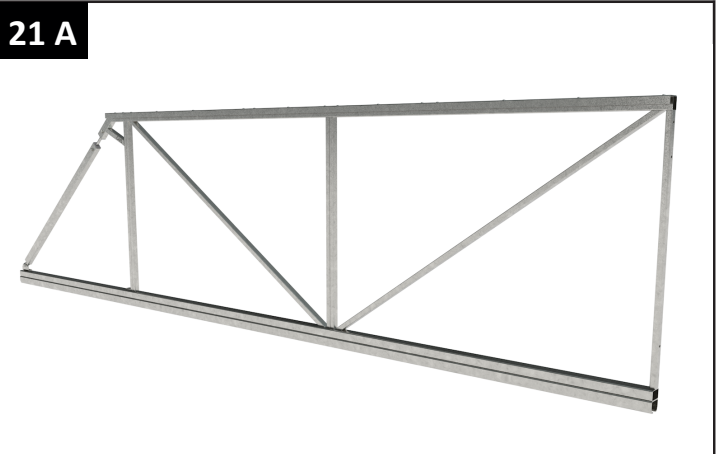
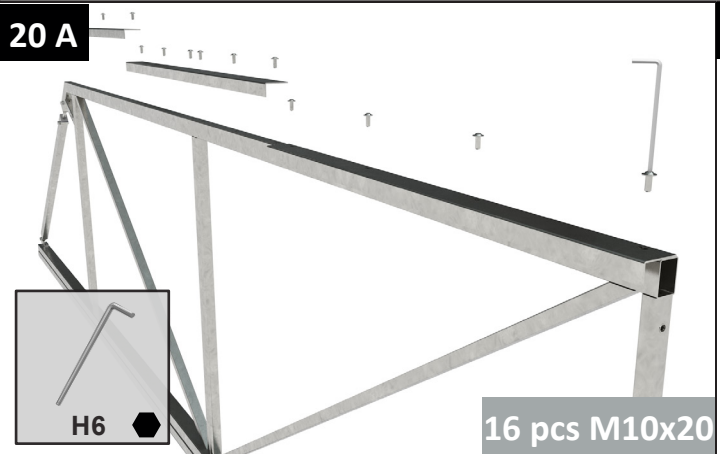
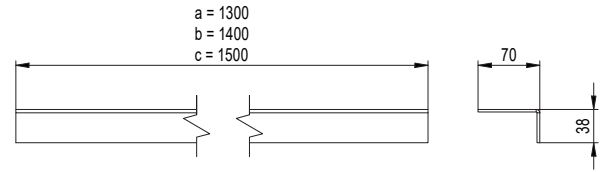
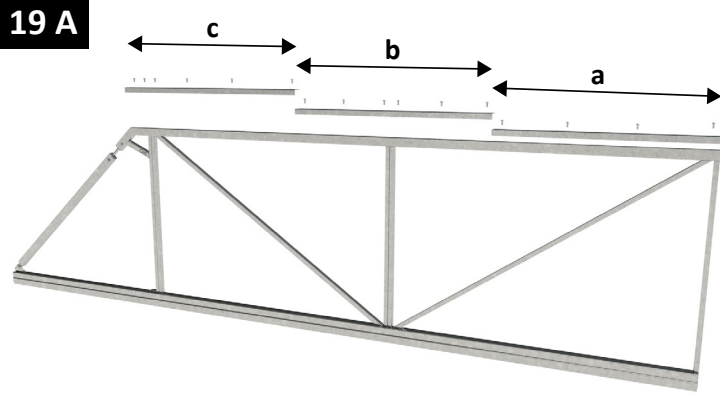

B - RIGHT OPENING

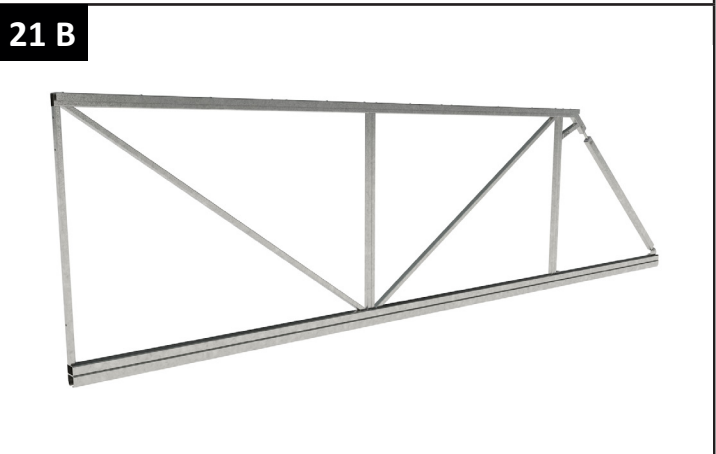
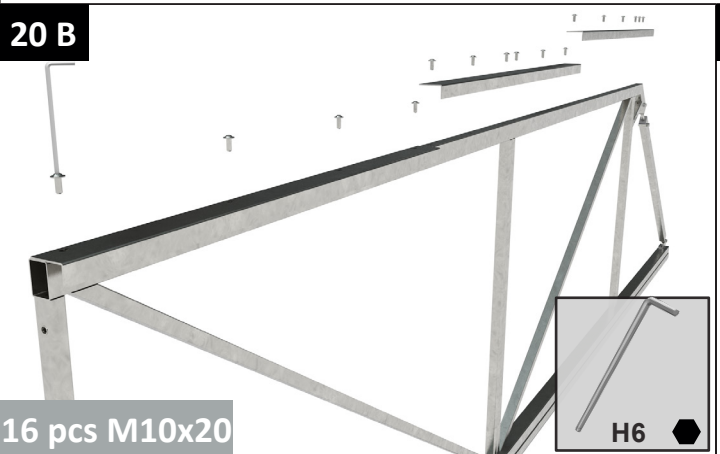
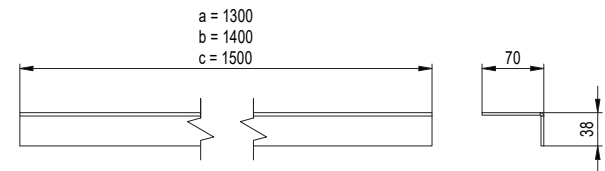
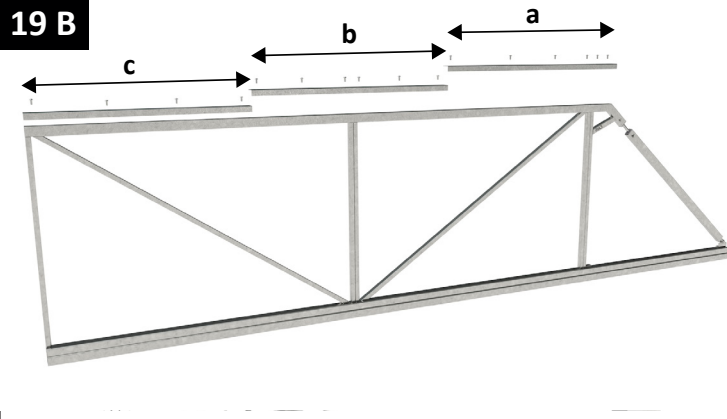

22

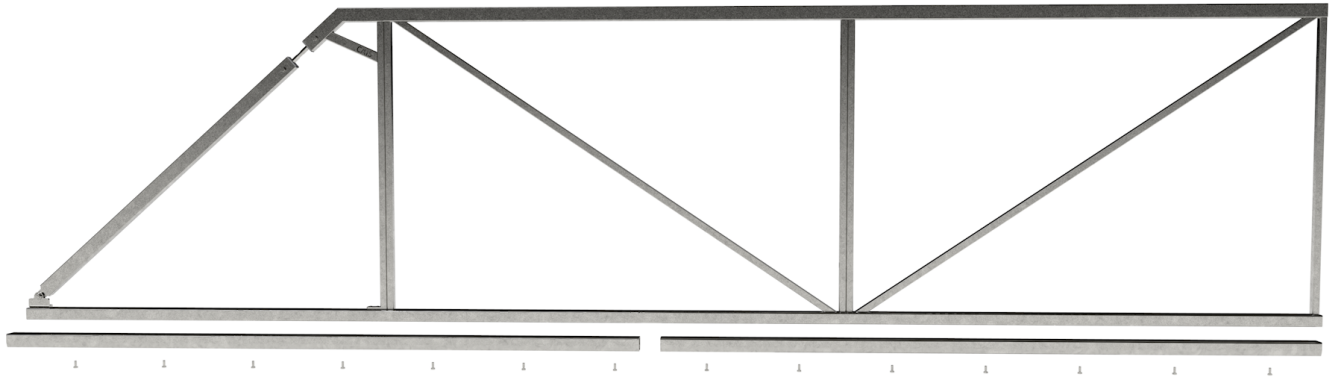

23

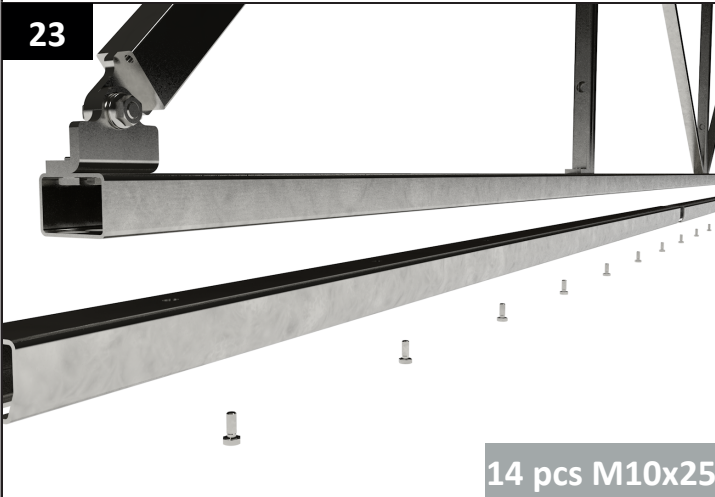

24

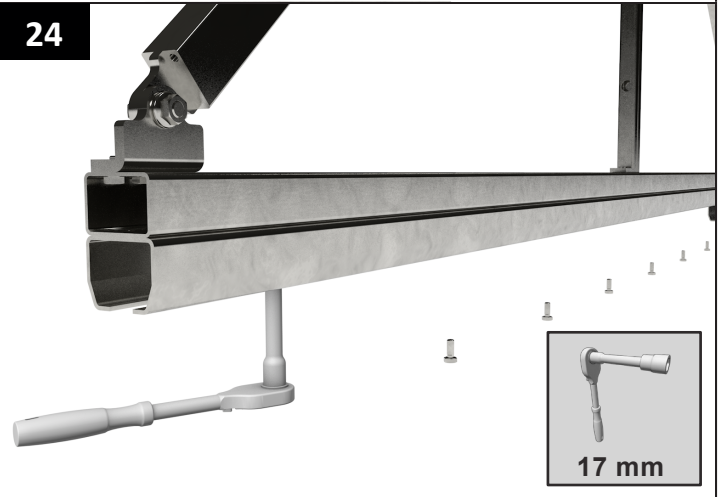

25



CONSTRUCTION SITE PREPARATION

1

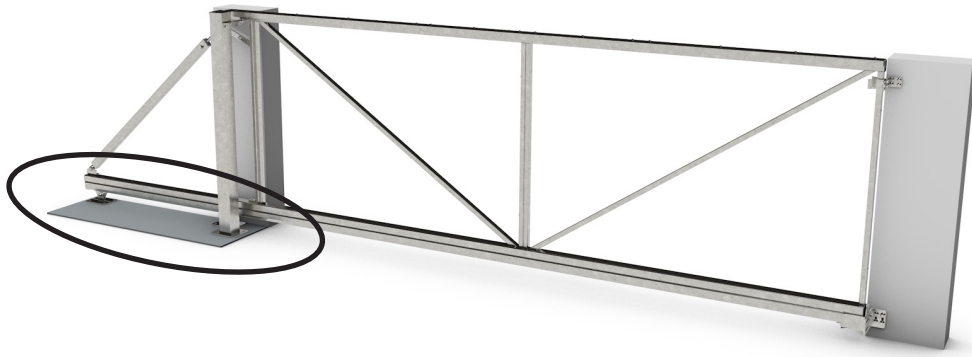

VIDEO
MANUAL



2

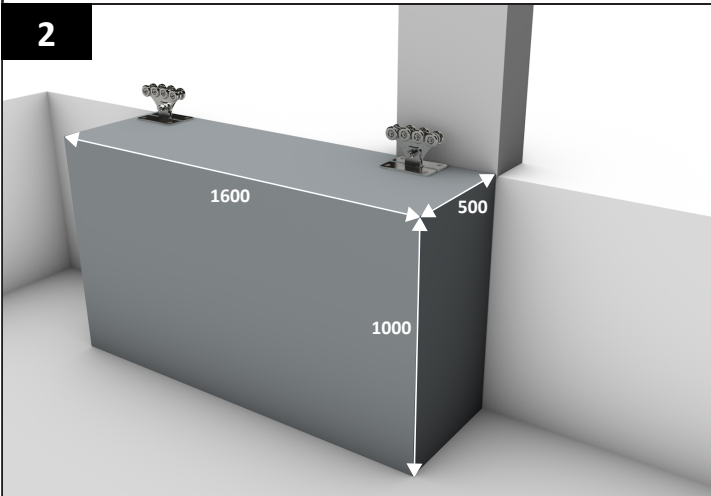

3

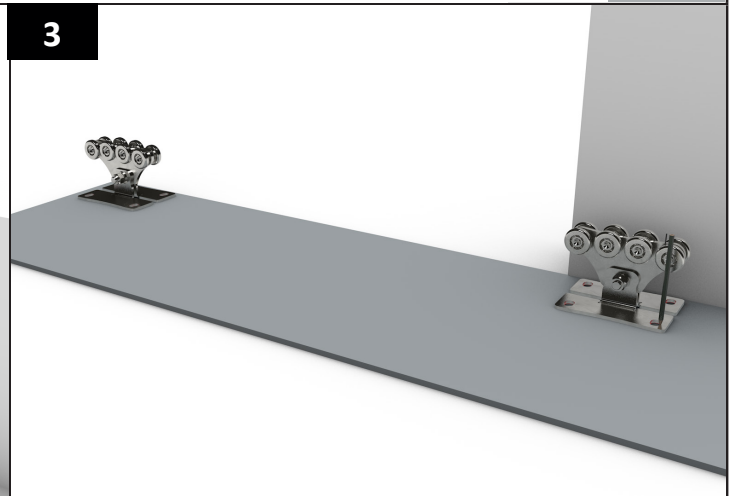

4

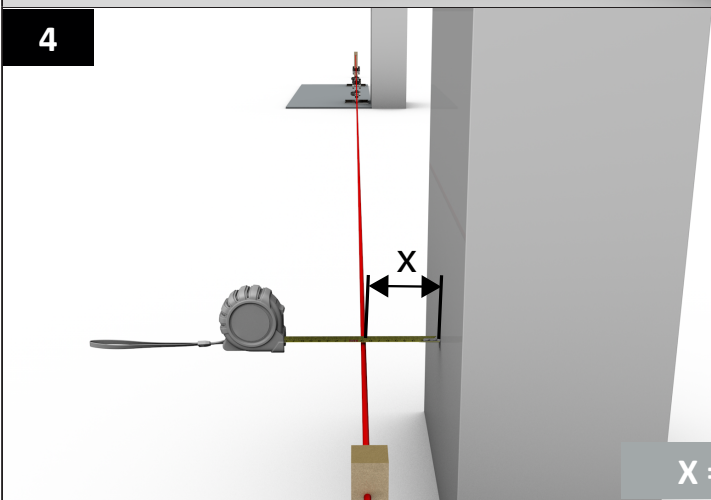

5

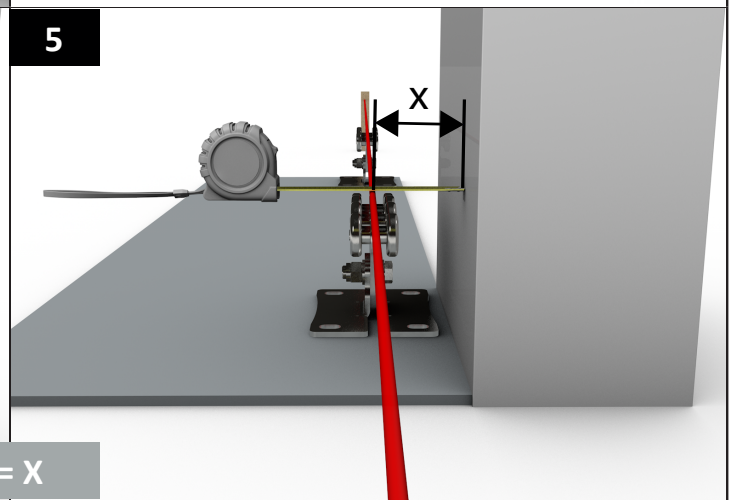

$X = X$

6

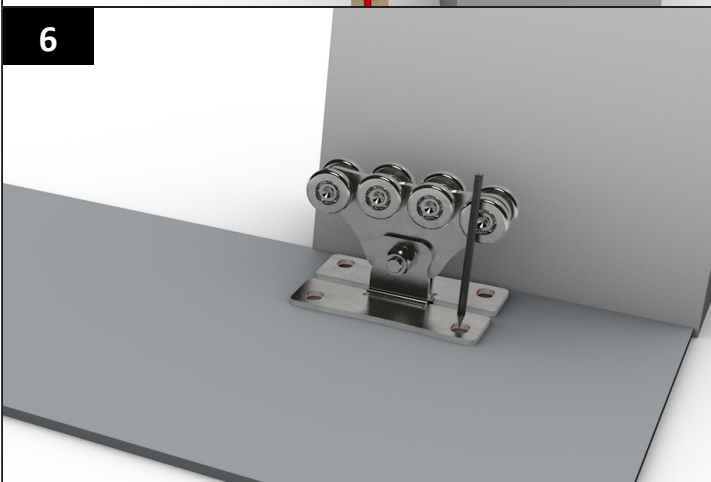

7

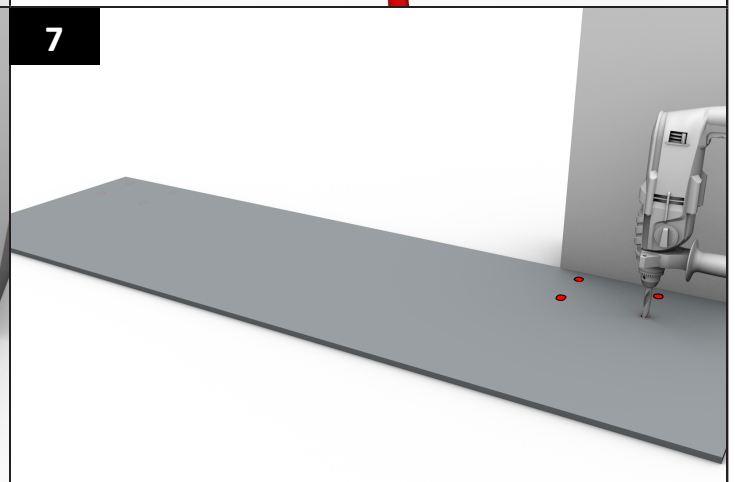

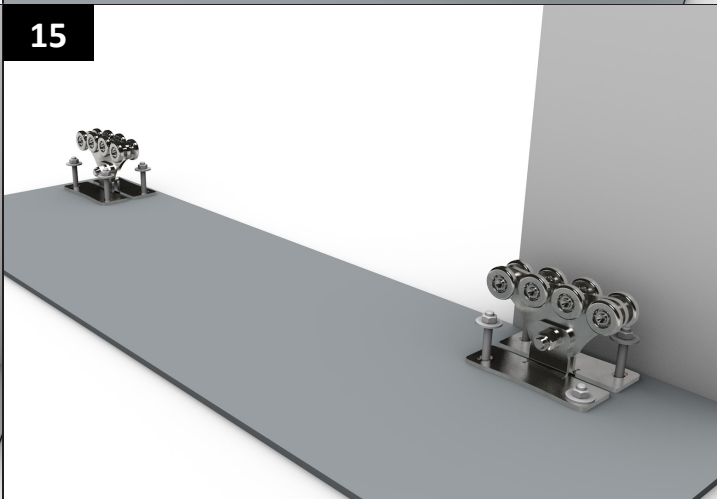
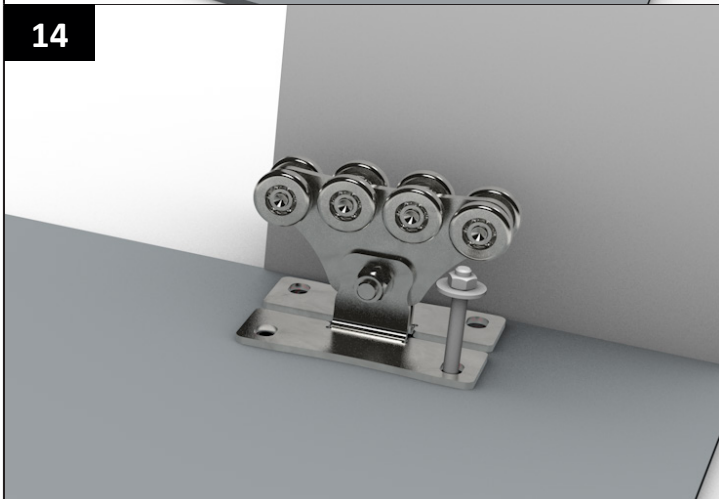
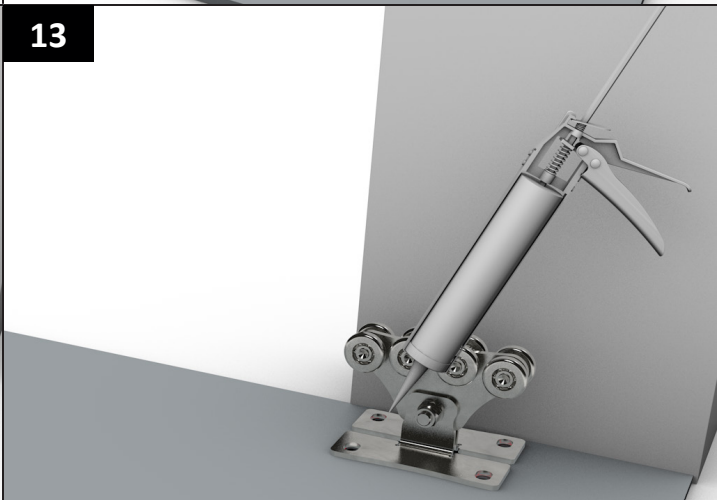
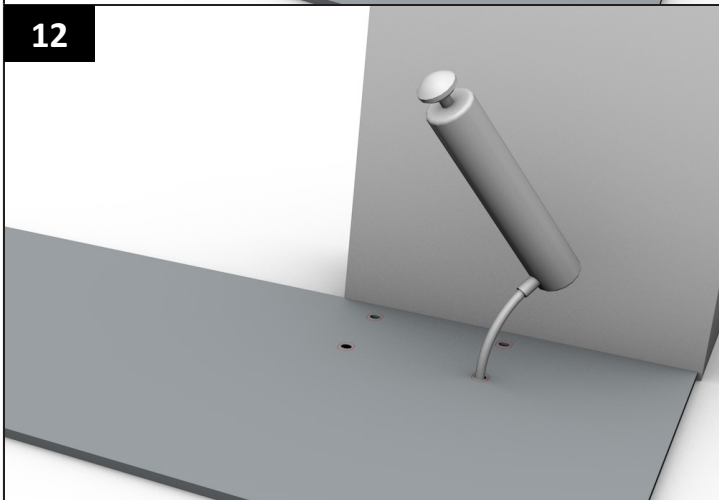
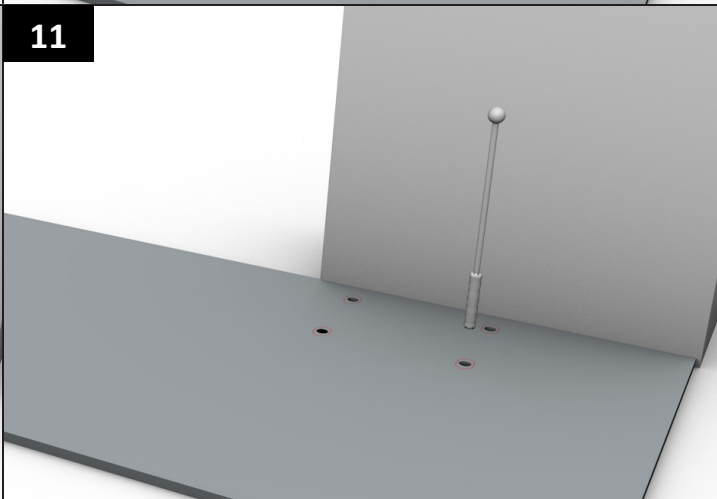
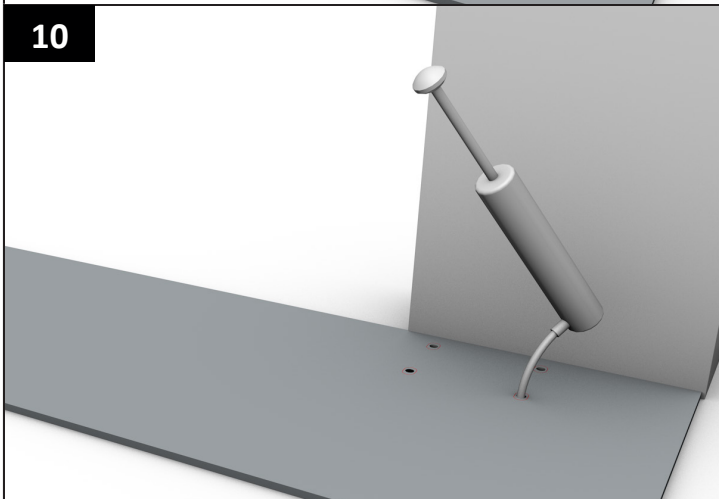
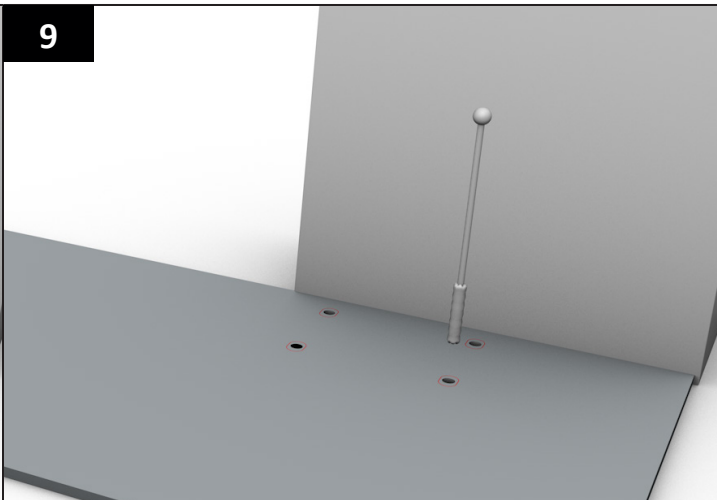
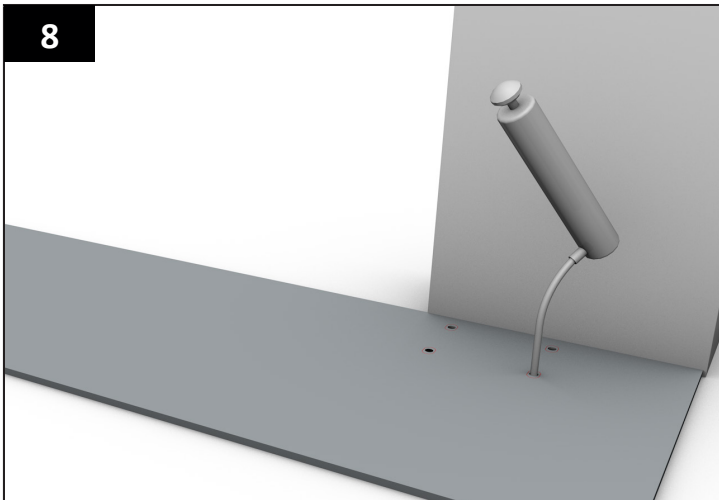

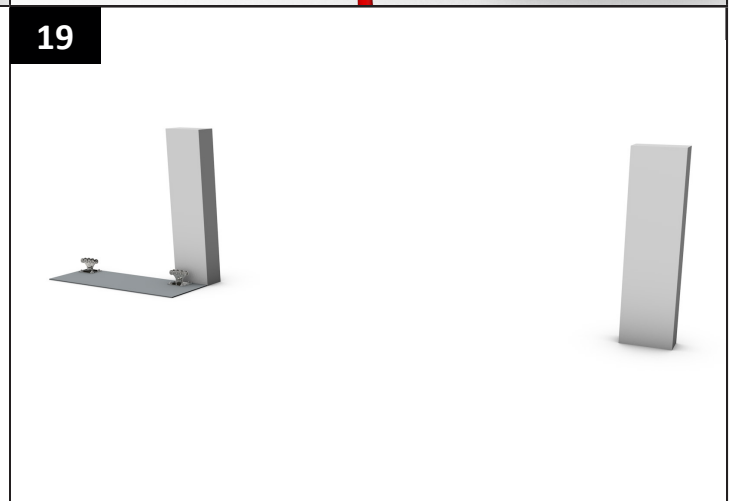
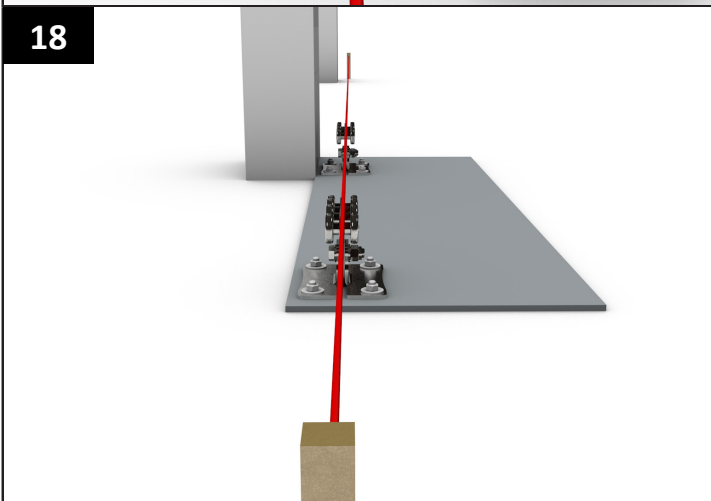
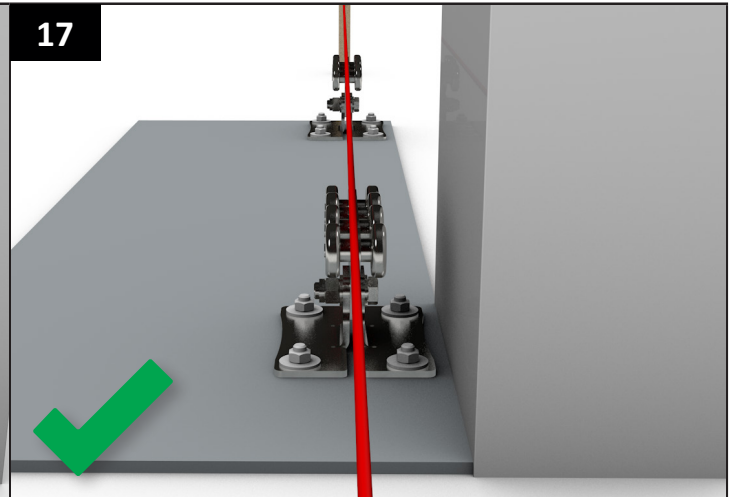
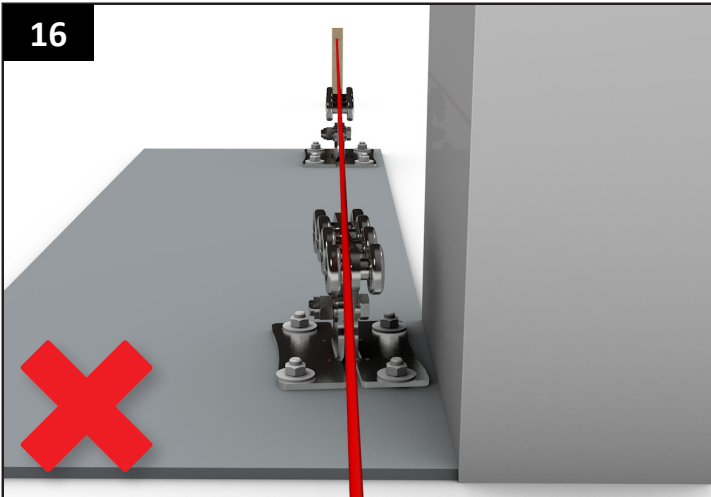

INSTALLATION MANUAL

1

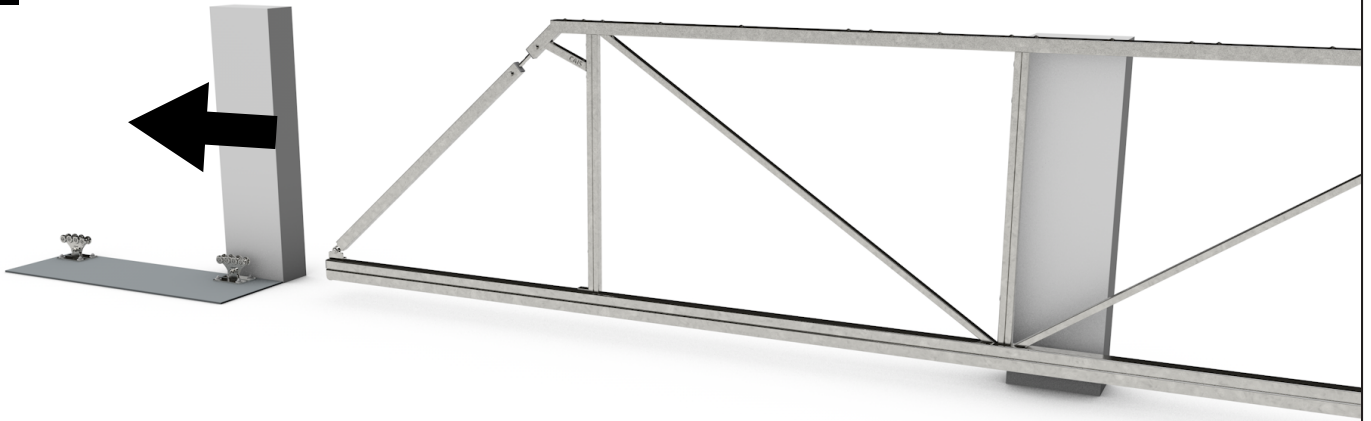

2

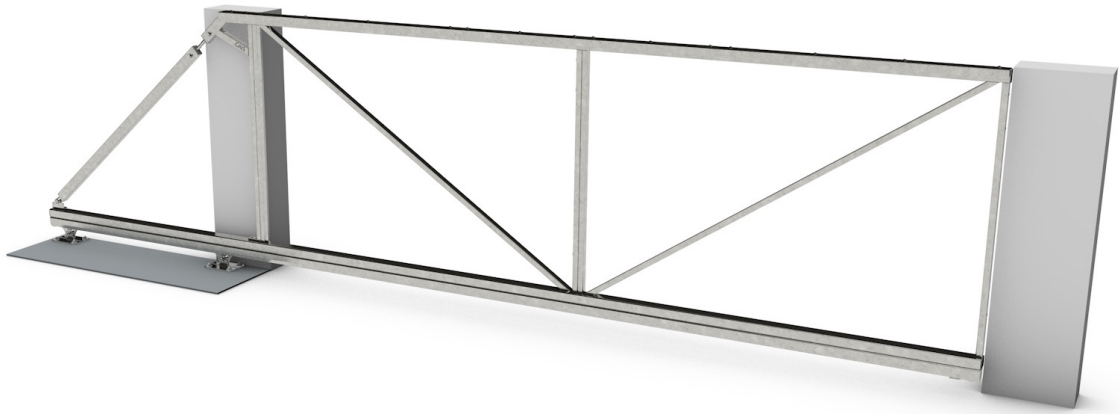

3

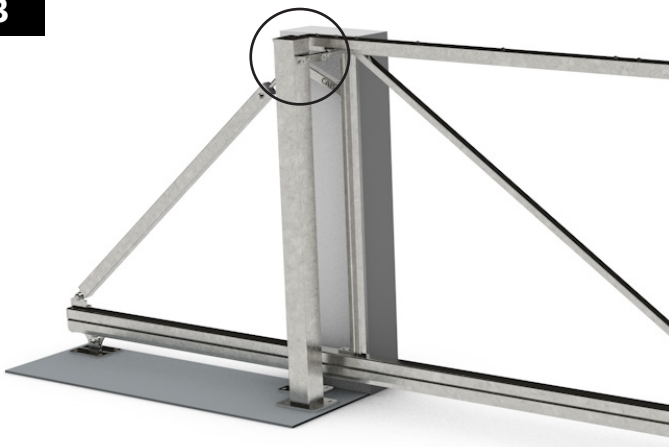

4



5



6



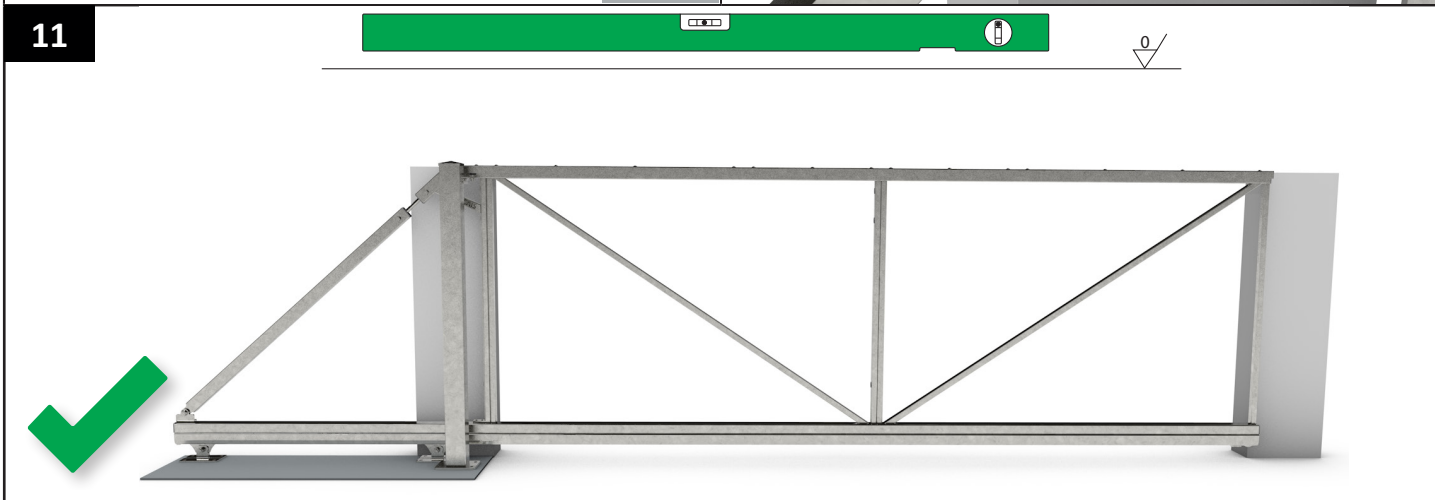
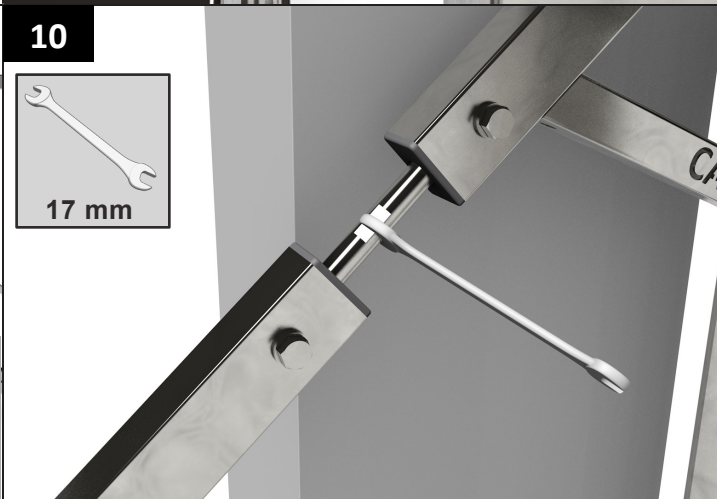
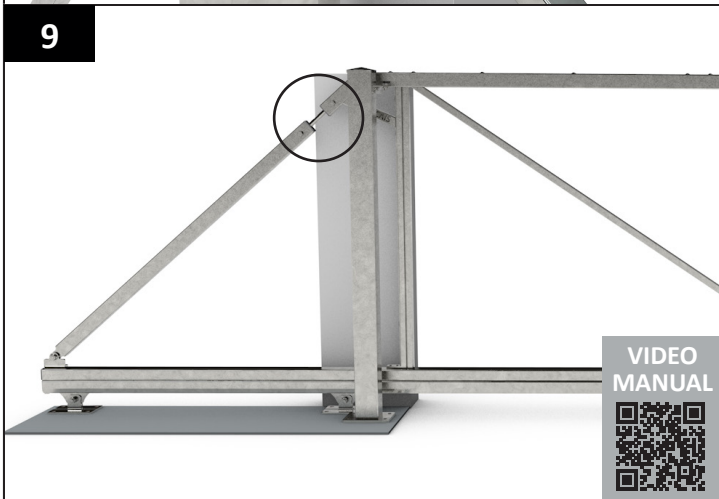

13



14



15



16

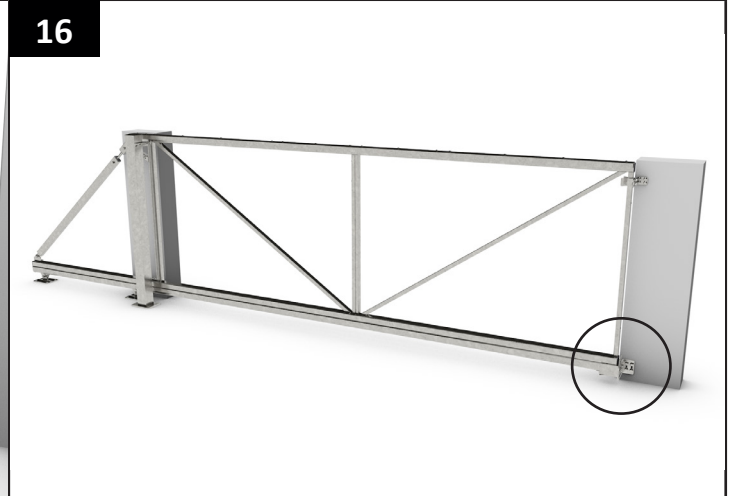

17

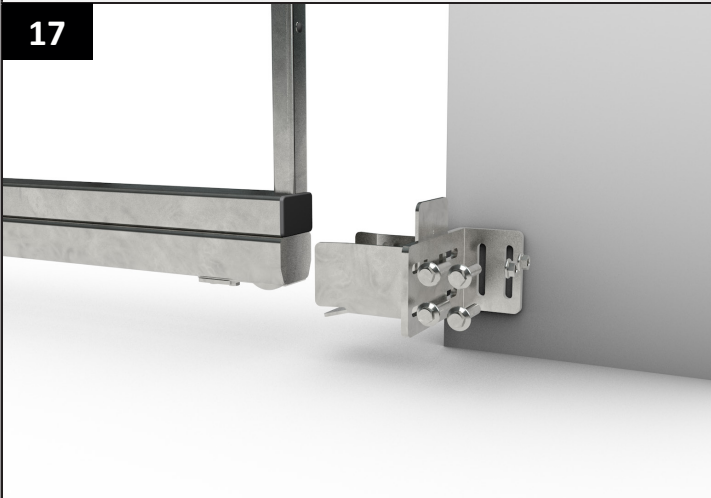

18

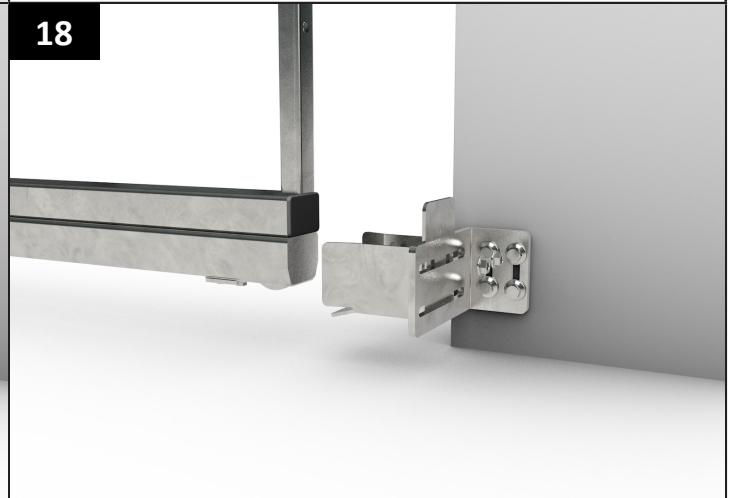

19

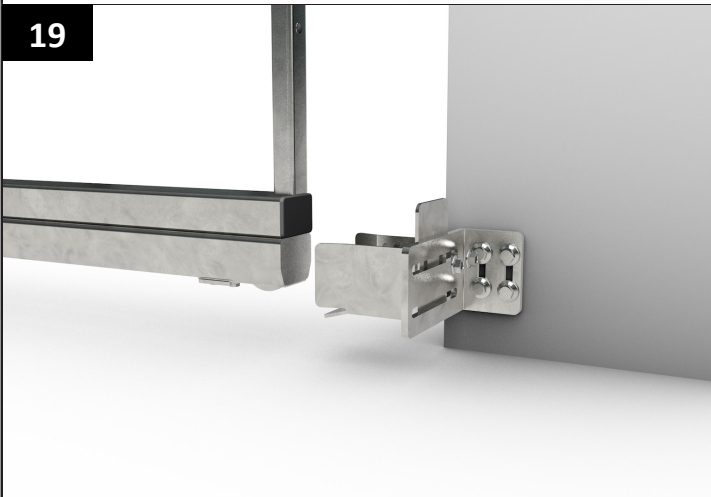

20

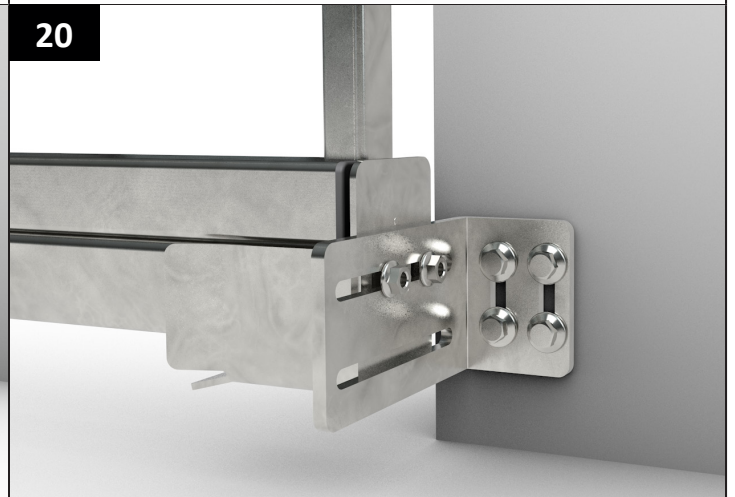

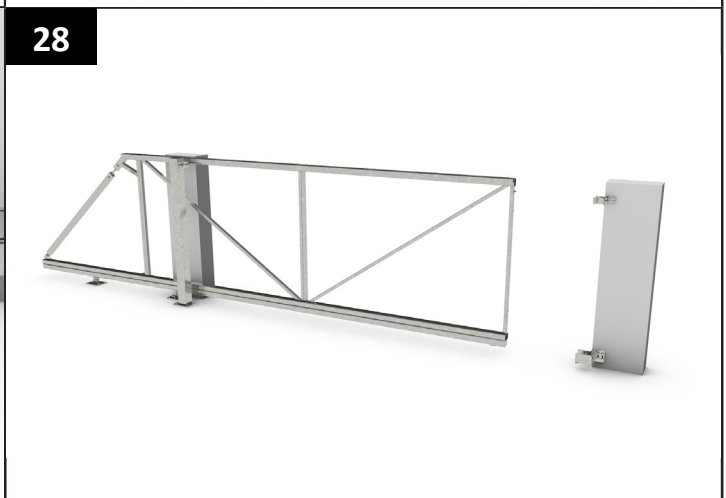
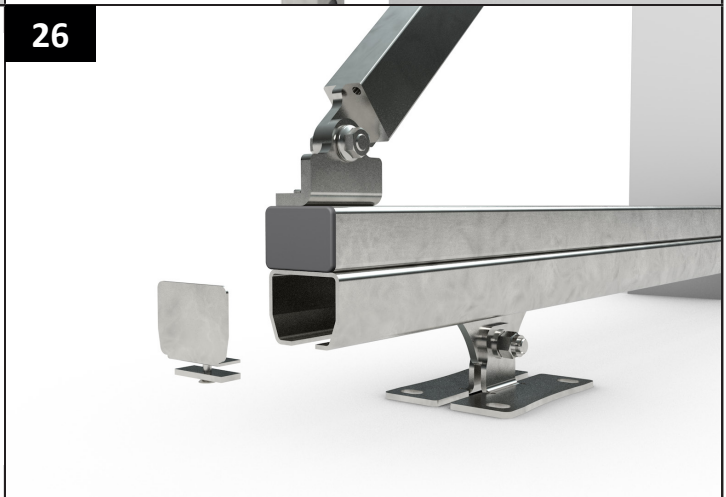
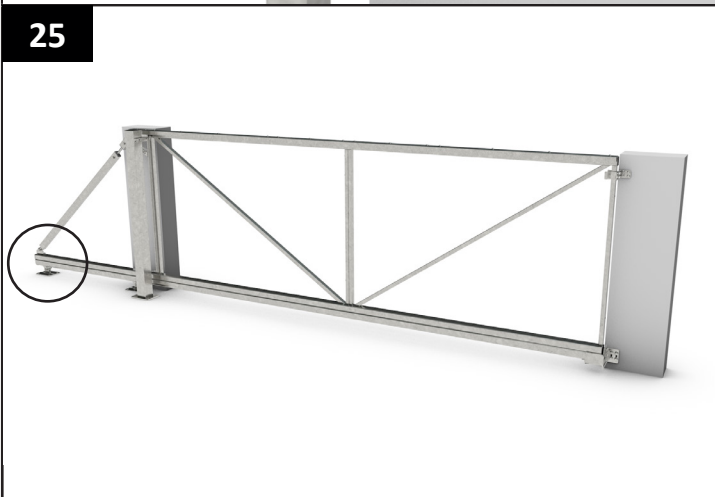
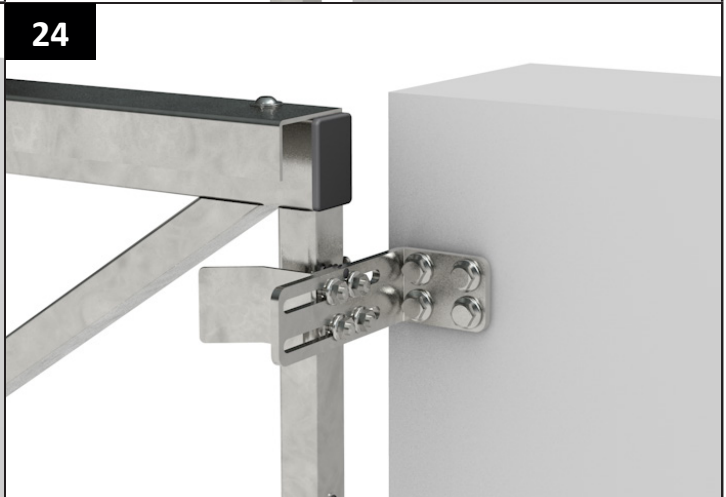
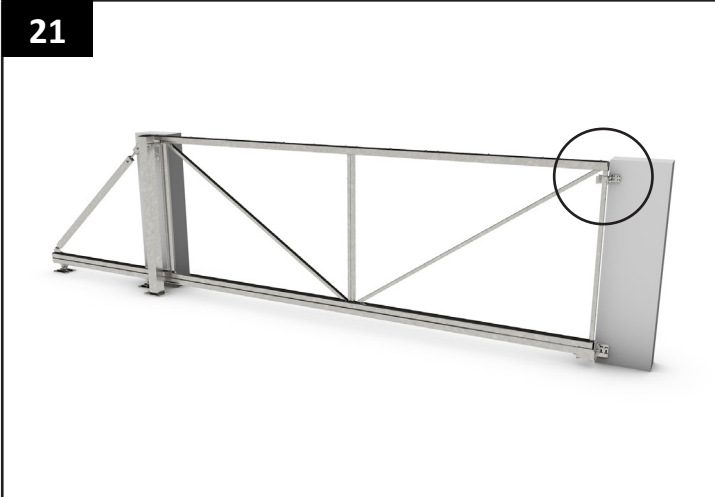

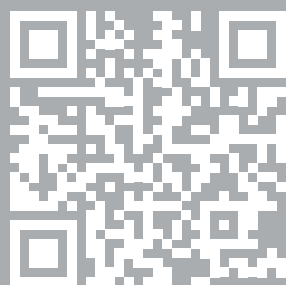

WWW.CAIS.EU